



## Mobile Suction Machine For Cleaning Sewer Manholes and Water Entrances



1



2



3

IPWT, the renowned name in sewer cleaning and storm drainage systems, now offers time and cost-saving, maintenance-free, vehicle-mounted, PTO (power take-off) driven **GULPIT® Suction Machines**.

**GULPIT®** is a product of IPWT's in-house development program, that lets you use the truck engine for all cleaning operations, adding to the fuel economy.

**GULPIT®** is custom-made so as to snugly fit onto any commercial truck chassis.

**GULPIT®** is especially designed to make the task of removal of sludge materials, easy and effective. The effluent liquids and sludge materials are sucked from the sewer manholes and water entrances into its own tank and then transported and discharged at the right place in an environmentally friendly and hygienic manner.

**GULPIT®** consists of a tank with 360° rotatable suction boom and a superior dual cooled (air + water-cooled) vacuum pump or compressor mounted on the vehicle. The power to the pump is given from the truck engine through PTO, thus creating vacuum in the tank. Controls are provided for tank-tipping, door-opening, boom valve-opening and boom lift on an electro-control pendant.

The tank shall be cylindrical in shape and shall be fabricated from mild steel sheets as per IS:2062 and shall be electrically welded with suitable reinforcement to prevent from collapse and elongation in vacuum and pressure conditions.

**GULPIT®** machines are custom-made in capacities depending on gross vehicle weight (GVW) of truck chassis (suggested tank capacities : 1500 lts. on 5 ton GVW chassis ; 3000 lts. on 10 ton GVW chassis ; 6000 lts. on 16 ton GVW chassis ; 9000 lts. on 25 ton GVW chassis).

**GULPIT®** totally satisfies the underground cleaning needs of municipalities and sewer authorities, industrial plants, military and utility companies...all at once.

Maintenance is virtually nil for these rugged machines and at the time when they need to be serviced, our after sales service is just a phone call away!

The Vehicle Mounted Suction Unit shall be robust in construction and shall be used to create a vacuum for syphoning out mud and slurry, grit and other material from sanitary, storm and sewerage systems. The unit shall be capable of syphoning out material from a depth of 8 mtr.

1. Max-size **GULPIT®** Deep suction machine (10000 lts.) ; on 25 ton GVW chassis ; supplied to Ahmedabad Municipal Cororation in 2014.
2. Midi-size **GULPIT®** suction machine (6500 lts.) ; on 16 ton GVW chassis ; supplied to Municipal Corporation of Greater Mumbai in 2013.
3. Mini-size **GULPIT®** mud-sucker suction machine (1500 lts.) ; on 5 ton GVW chassis ; supplied to Municipal Corporation of Greater Mumbai In 2013.

MAINTENANCE EQUIPMENT  
drainage

Schematic diagram showing **GULPIT**® sucking from deep manholes which are inaccessible to manual labour and also dangerous due to toxic gases present in the drain

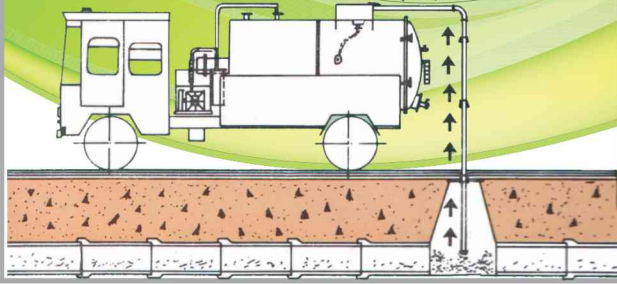

**A SIMPLE CLEANING PRINCIPLE :**

The **GULPIT**® Suction Machine is driven and positioned near the manhole which has to be cleaned. The suction boom is rotated and positioned such that hose remains vertically above the manhole. The required number of suction hose segments are connected with the help of quick couplings to the boom and the other end is dipped inside the sludge to be sucked. The PTO is then engaged to create the vacuum inside the tank. Once the vacuum is created, the boom valve is opened and the sludge is sucked from the manhole into the tank. The sucked materials can be discharged by tipping the tank hydraulically.

**GULPIT**® requires only two operators for carrying out complete operation and maintenance with ease.



4. Mid-size **GULPIT**® Kanal Muller design suction machine (6000 lts.) ; on 16 ton GVW chassis ; supplied to Municipal Corporation of Greater Mumbai in 1975 and 1994.

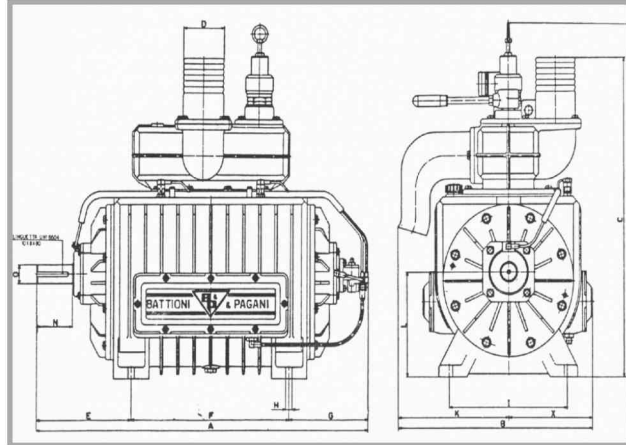

**THE HEART OF EVERY GULPIT® SUCTION MACHINE :**

The heart of every **GULPIT**® is provided by quality **BATTIONI PAGANI S.P.A. (Italy)** or equivalent imported Vacuum Pump. The vane blades of the vacuum pump are of heat-resistant material with dual cooling system (air + water-cooled) to avoid overheating in tropical condition. Designed for utmost in capability and output, **BATTIONI** pumps create greater amount of vacuum (95%) for efficient suction and require negligible maintenance.

**BATTIONI PAGANI S.P.A., Italy** is an internationally renowned company and has been in this business for over 50 years. The imported vacuum pump provided by us is capable of producing over 90% vacuum and min. 1 bar discharge pressure which is impossible to achieve with locally manufactured pumps as these are not manufactured for specific purpose of sewage suction besides are of lower quality.



5. Midi-size **GULPIT**® gulley emptier suction machine (6000 lts.) ; on 16 ton GVW chassis ; supplied to Karnataka Urban Development Finance Company in 2003.

**ADVANTAGES :**

- Can clean sewer manholes and water entrances where normally manual cleaning is impossible due to inhuman conditions and poisonous gases
- Maintenance is virtually nil for first few years
- Easy to operate as no special skill is required
- Reduction of labour-oriented method of cleaning, thus upgrading dignity of labour
- Can be customised to suit any client's requirement
- Cleans blockage from the most inaccessible points in Sewer manhole and water entrances



Winner of the prestigious 'National Award for Import Substitution' in 1982 for Garbage Compactor



Dun & Bradstreet Rating : SE2A "High Performance Capability and High Financial Strength"



**INDUSTRIAL PLANTS & WASTE TREATMENT CORPORATION**

<b>Mumbai :</b> Suite B2, 34, Deonar Ancillary Industrial Complex, Deonar, Govandi (W), Mumbai 400 043. Tel. : 022 - 2556 1810 Fax : 022 - 2550 6590	<b>Mumbai Works :</b> Plot No. 71, Survey No. 238 (Part), Vasai Taluka Indl. Estate, Village Achole, P.O. Gokhivare , Tal. Vasai, Dist. Thane Tel. : 0250 - 2455 328	<b>New Delhi :</b> 25, National Media , Centre, Shankar Chowk , NH-8, Gurgaon 122 002 Tel. : 0124 - 400 8233 Fax : 0124 - 235 6906	<b>Chennai :</b> 7, Signet Home, 6th Avenue, Harrington Road, Chetpet, Chennai 600 031 Tel.:044-2836 5255 Fax:044-2836 3429	<b>Bangalore :</b> 72, Shalimar Apartments, 3, D'souza Road , Behind Devatha Plaza, Bangalore 560 025 Tel.:080 - 2224 0037 Fax:080 - 2224 0143	<b>Kolkata :</b> IPWT Corporation FD-450, Sector-III, Ground Floor, Salt Lake, Kolkata-700091 Tel.:033 - 4007 6049 Fax:033 - 4007 6049	<b>Ahmedabad :</b> Q-106 & 107, Shrinand Nagar - III, Vejalpur, Ahmedabad - 380 051
---	--	---	--	---	---	--

working our way towards...a cleaner environment